

PARKANSON BANDSAWS

***Column Type CNC
Double Miter Cutting
Bandsaws***

**Fully automatic twin column CNC feeding and mitering
bandsaws for cutting beams, pipes and solids.**

Model: 650DMA/ 800DMA / 1000DMA/ 1300DMA

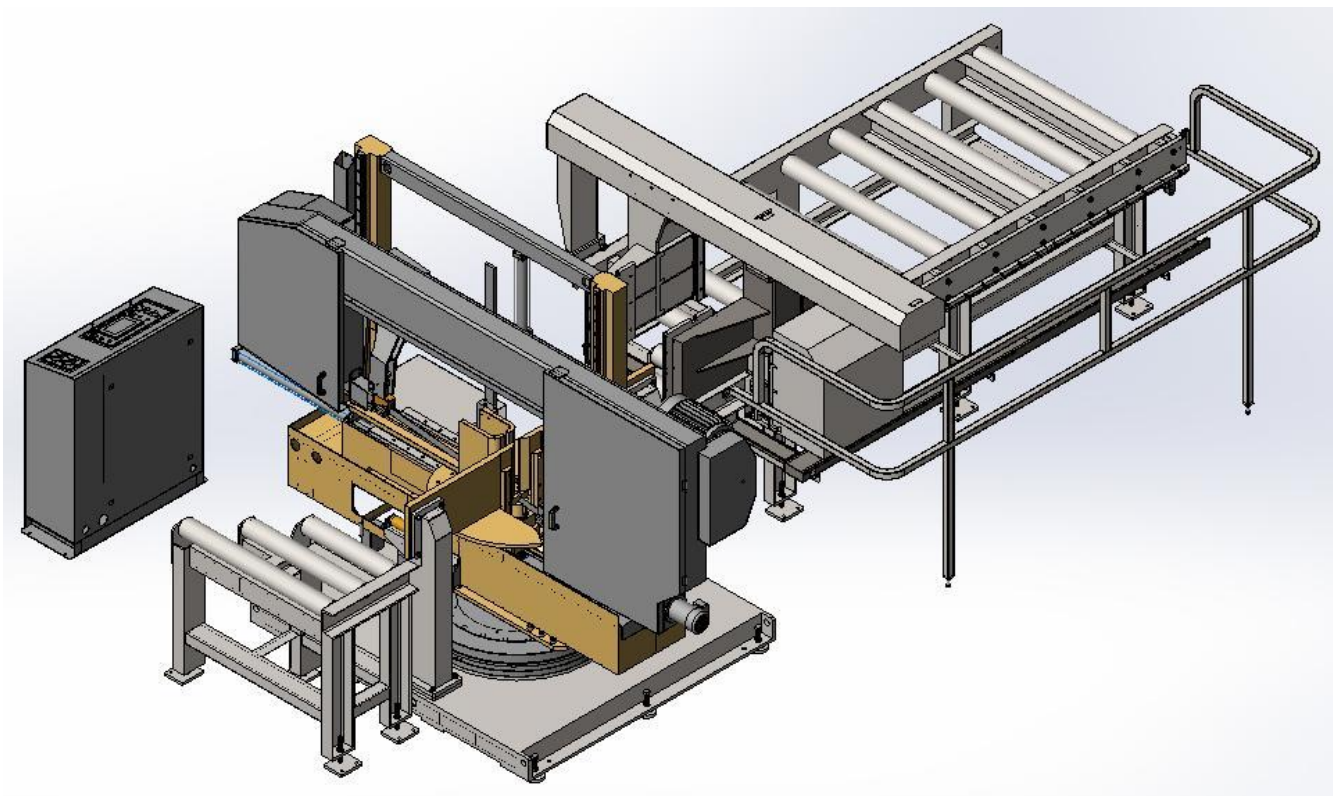

Features:

1. For cutting variable angle from 60° left to 45° right.
2. Twin columns with leaner guide ways for cutting more stable and accuracy.
3. Inclination of the saw blade (5°) to reduce the initial blade impact when cutting beams and square tubes.
4. The NC control allows setting and memorizing 250 cutting programs, with different cutting lengths; quantities and angles.
5. The material feeder with Steel guides; precision rack and pinion, powered by servo motor with 2300mm feed stroke.
6. Automatic positioning of guide arm.
7. Mist coolant system with minimal lubrication to cut long pipe and profile without any leakage of coolant. (Option)

Standard equipments

1. Variable blade speed drive
2. Hydraulic blade tension.
3. Laser liner
4. Working light.

Optional equipments

1. 3M feeder extension unit
2. Mist lubrication
3. 3M Roller table
4. 3M Powered roller table

Specifications:

Model		650DMA	800DMA	1000DMA	1300DMA				
Cutting Capacity (mm) (H x W)	●	450	600	650	760				
	■	440 x 650	550 x 800	650x1000	700 x 1300				
	■ R/L 45°	440 x 420	400 x 520	450x650	650 x 850				
	■ L 60°	340 x 270	400 x 340	450x420	650 x 550				
	■ R 60°	340 x 440	--	--	650 x 550				
Motors	Saw Blade	3.75 KW	5.5 KW	7.5KW	10.0KW				
	Hydraulic	0.75 KW	1.5 KW	2.2KW	2.2KW				
	Coolant	0.1 KW	0.2 KW	0.2KW	0.2KW				
Blade Size (mm)		5400 x 41 x 1.3	6740 x 41 x 1.3	7750x54x1.6	9300x67x1.6				
Blade Speed (M/min)		20-90							
Blade inclination		5°							
Single Feed Stroke		2300, 5300(option), 8300(option) mm							
Vise Clamping Width		10-670mm	80-820 mm	200-1020 mm	150-1340mm				
Working height (mm)		730	955		900				
Packing Dimensions (mm)		Saw	Feeder	Saw	Feeder	Saw	Feeder	Saw	Feeder
	Length	1250	3100	1800	3100	1830	3100	2300	3100
	Width	2650	2000	3400	2100	3680	2100	4350	2100
	Height	1850	1500	2500	1800	2600	1800	2600	1800
Net Weight (App.) Kg		3000	1900	5200	2500	5600	2500	7400	2700

* The specifications subject to change without notice



Capital Equipment Machinery Sales
 1/10 Renewable Chase
 Bibra Lake WA 6163
 Ph: (08) 9410 9500 Fax: (08) 9410 9555
 www.capitalequipment.biz